

## SPECIFICATIONS

### CODES AND STANDARDS

Generac Mobile products are designed to the following standards:



TIER 4 FINAL  
EMISSIONS



NATM



Picture shown may not reflect actual configuration.

### ENGINE SYSTEM

- Isuzu® 4JJ1T
- Diesel fueled
- EPA Final Tier 4
- 4-cylinder turbocharged
- 3.0 L displacement
- Power @ 2,000 rpm: 73 hp (54 kW)
- Air filter: Dry type cartridge
- Positive Air Shutoff - Electronic

### FUEL SYSTEM

- Fuel tank capacity - US gal (L):
  - Total: 173 (654.9)
  - Usable: 160 (605)
- Fuel consumption rate: 3.55 gph (13.44 Lph)
- Minimum run time: 45 hr
- Fuel filter: Spin-on

### COOLING SYSTEM

- Liquid cooled
- Capable of operating at -40 to 100°F (-40 to 37.8°C) ambient
- Coolant capacity: 6.3 qt (6.0 L)

### ENGINE LUBRICATION SYSTEM

- Oil filter: Spin-on
- 500-hr service interval\*\*

\* Data based on engine manufacturer and field test data after 100-hr engine break-in period. Actual results may vary, according to factors such as age and maintenance of equipment, environmental conditions, and fuel density. For fuel and maintenance recommendations, see owner's manual.

\*\* For maximum service interval, replace oil filter after 50-hr break-in period. For oil filter model number, see parts manual.

## SPECIFICATIONS

### HEATER

- Type: Flameless, self-contained
- Heat produced: Up to 485,000 BTU/hr (142.1 kW/hr)
- Max Temperature: 180°F (82.2°C)
- Air flow: 2,650–5,500 ft<sup>3</sup>/min (75–155.7m<sup>3</sup>/min)
- Air discharge: Two 12 in (30.5 cm) outlets
- Efficiency: Up to 92%
- Heat transfer fluid (HTF):
  - Pump: Variable displacement piston pump
  - Tank capacity: 14 US gal (53 L)
  - System capacity: 25 US gal (95 L)
  - Hydraulic oil type: Mobile DTE10 ISO VG68

### HYDRAULIC LOOP

- Pump: Metaris 63 cc variable displacement piston pump
- Two hydraulic oil filters – 9 and 20 microns

### PROTECTION

- Self-contained
- Automatic shutdown for high hydraulic oil temperature, high hydraulic oil pressure, engine over speed, low engine oil, low fuel, and low hydraulic oil
- 110% containment

### ENCLOSURE

- All steel construction. UV and fade resistant white polyester powder paint
- Fully lockable – including control box door, service access doors, and fuel fill
- Rear storage for two 12 in × 25 ft air ducts
- Operating and safety decals
- Document holder with owner's manual – includes wiring diagrams
- E-stop

### TRAILER

- 2-5/16 in ball hitch – adjustable height
- Tongue jack
- Electric brakes
- Transportation tie downs
- Forklift tubes
- DOT approved lights: Tail, brakes, and directional lights
- One 6,000 lb (2,721.6 kg) axle
- Tires: ST235/80R16, 3,500 lb
- Plug adapter. Round 7 spade (SAE J2863)

### CONTROLS

- Murphy controller- PV450
- TFT color graphic LCD display with LED backlight

### BATTERIES

- Two 12 V, 950 CCA, wet cell batteries
- Electrical system rating: 12 V

### OPTIONS\*

- Spare tire and carrier
- 60/40 coolant
- One 20 in (50.8 cm) air discharge outlet
- 3 in. pintle ring – adjustable height
- Transport Canada - Please Call

\*Additional options may be available. Contact a sales representative or the factory for current options.

## SPECIFICATIONS

### DIMENSIONS

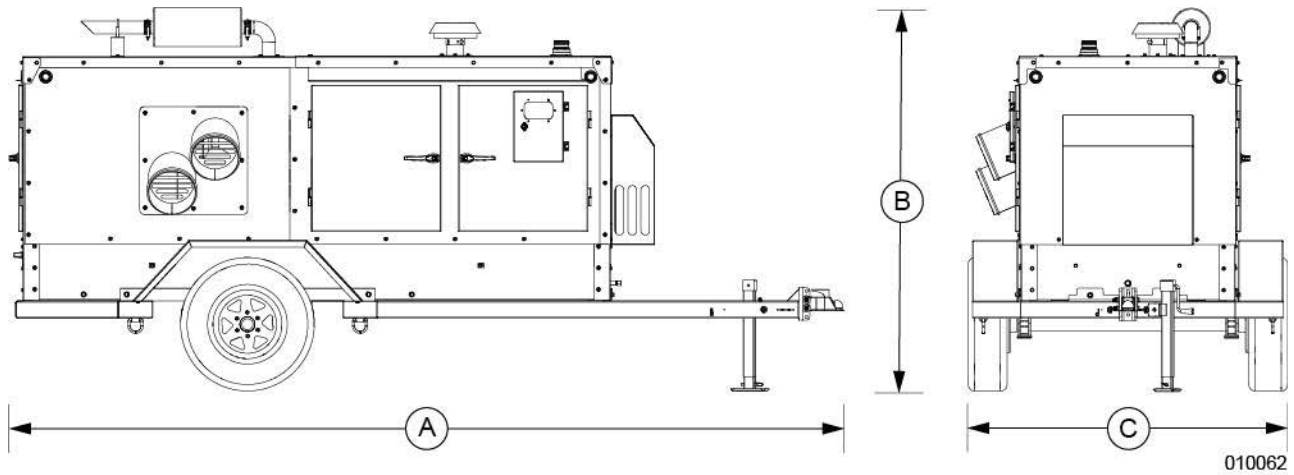

A	B	C
191 in (4.85 m)	88 in (2.24 m)	72 in (1.83 m)

### WEIGHT

- Dry: 5,540 lb (2,513 kg)
- Operating: 6,400 lb (2,903 kg)

### WARRANTY

1 year, unlimited hours

### FOR MORE INFORMATION

Owner's manual is available at [www.generacmobileproducts.com/service-support/manuals](http://www.generacmobileproducts.com/service-support/manuals)

**YOUR FACTORY RECOGNIZED GENERAC MOBILE DEALER**

*Specification characteristics may change without notice. Dimensions and weights are for preliminary purposes only. Please contact a Generac Mobile Products Authorized Service Dealer for detailed installation drawings.*