

## STATIONARY HYPERCUBE (SLT-D)

### SPECIFICATIONS

#### ENGINE SYSTEM

- Kubota® Z482
- Diesel fueled
- EPA Tier 4 Final
- 2 cylinder
- 0.479 L displacement
- Power @ 1,800 rpm: 5.1 hp (3.8 kW)
- Air filter: Dry type cartridge

#### Fuel System

- Tank usable capacity: 64.4 US gal (240 L)
- Fuel consumption – lights only: 0.214 US gph (0.8 L/hr.)
- Run time – lights only: 300 hr.

#### Cooling System

- Liquid cooled

#### Lubrication System

- Oil filter: Full flow, spin-on type

#### GENERATOR

- Alternator Rating: 4.2 kW, 120/240 V, 60 Hz
- System Output: 2 kW

#### CONTROLS

- Controller with timer activation
- Dusk to dawn
- Lights On/Off

#### TRANSPORT

- 18 units per 48' flatbed (dry)
- 16 units per 48' flatbed (with fuel)



Picture shown may not reflect actual configuration.

## STATIONARY HYPERCUBE (SLT-D)

### LIGHTS

- Four 320 W LED fixtures
  - 360° illumination
  - Lm/fixture: 46,000
  - Total lm: 184,000
- Coverage @ minimum 0.5 ft-c:
  - Standard (forward) configuration, 60° tilt: 19,441 ft<sup>2</sup> (1,806 m<sup>2</sup>)
  - 360° lights, 60° tilt: 33,496 ft<sup>2</sup> (3,112 m<sup>2</sup>)
  - 360° lights, 0° tilt: 4,304 ft<sup>2</sup> (400 m<sup>2</sup>)

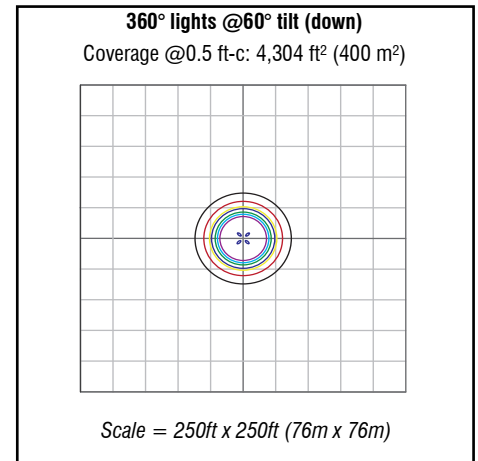
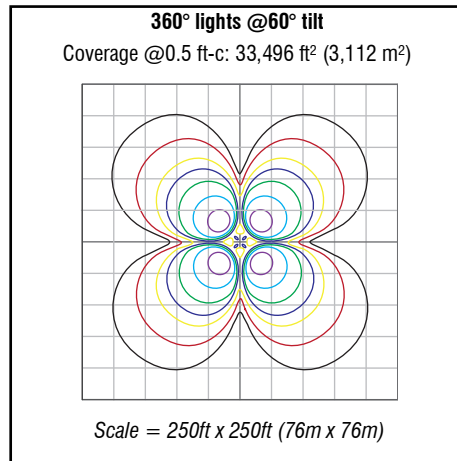
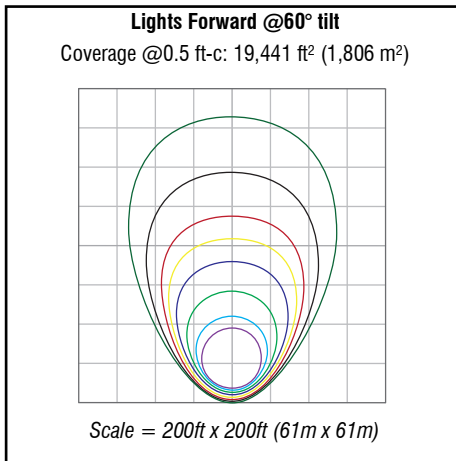

### ELECTRICAL SYSTEM

- 1 inlet, 20 A, 240 V, L14-20P
- 1 outlet, 20 A, 240 V, L14-20R
- 2 outlet, 15 A, 120 V, GFCI 5-15R

### MAST

- Galvanized construction with 6 sections
- Leveling “bubble” indicators to assist with setup
- 340° manual rotation with mast fully extended

### ENCLOSURE

- 5 Lockable doors for ease of service and maintenance
- Galvanized base-frame-mast / Powder coated panels
- Multi-lingual operating and safety decals
- Document holder with owner’s manual
- Sound rating: 60 dB(A) @ 23 ft. (7 m)
- 110% fluid containment with drain plug
- Center lifting point
- Fork lift pockets on all 4 sides
- Extended fork pockets to protect enclosure during lifting
- LED Drivers mounted inside enclosure
- Step for easy access to adjust lights
- Access to power cable outlets when doors are locked

### DIMENSIONS

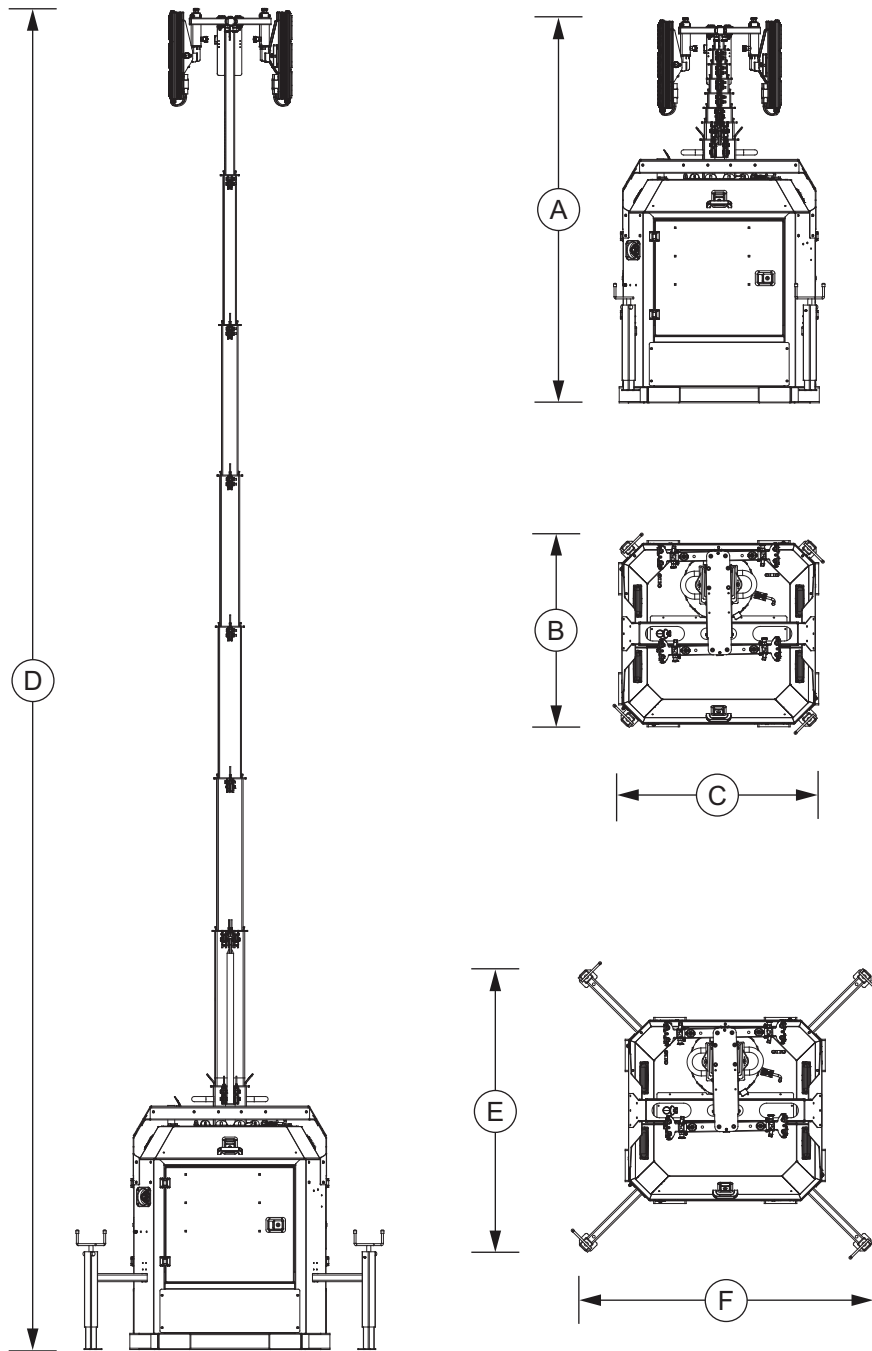

| A                   | B                   | C                   | D                | E                   | F                   |
|---------------------|---------------------|---------------------|------------------|---------------------|---------------------|
| 93.9 in<br>(2.39 m) | 48.5 in<br>(1.23 m) | 51.5 in<br>(1.31 m) | 27 ft<br>(8.2 m) | 68.3 in<br>(1.74 m) | 73.3 in<br>(1.86 m) |

### WEIGHT

- Dry: 2,389 lb. (1,084 kg)
- Operating: 2,839 lb. (1,288 kg)

## STATIONARY HYPERCUBE (SLT-D)

### STANDARD MODELS

- Standard Generac configurations

|                    | SLT-D CUBEHYPRK2<br>0°F (-18°C)<br>Standard | SLT-D CUBEHYPRK2CW<br>-20°F (-29°C)<br>Cold Weather |
|--------------------|---|---|
| Air intake heater  | •   | •   |
| Coolant heater     |   | •   |
| 60/40 coolant      |   | •   |
| Heated fuel filter |   | •   |
| 720 CCA battery    |   | •   |

- Optional: Diffused LED kit – reduces glare and minimizes light pollution

### AMBIENT CLIMATE RATINGS

- Wind rating: 68 mph (110 km/h)
- Maximum air temperature: 120°F (49°C)

### CERTIFICATIONS

- CSA with cold-weather configuration

### WARRANTY

- Tower: 1 year, unlimited hours/ 2 years, 2,000 hours
- LED modules and drivers: 5 year limited warranty

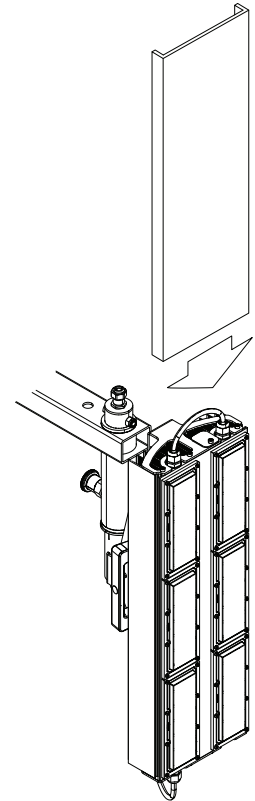

Diffused LED Kit: 4 diffusers slide onto light fixtures  
Order Kit PN: A0000773887

\* All measurements are approximate and for estimation purposes only.



Specification characteristics may change without notice. Dimensions and weights are for preliminary purposes only. Please consult a Generac Mobile Authorized Service Dealer for detailed installation drawings.